

| Mode 2 EV Charging Cable

IC-CPD (In Cable Control and Protection Device)



User Manual

Important:

Read this User Manual before you start using the device!

CONTENTS

SAFETY INFORMATION.....	2
PRODUCT INFORMATION.....	3
OPERATION INSTRUCTIONS.....	5
TEMPERATURE CONTROL (optional).....	18
INSTALLATION (optional).....	19
FAULT HANDLING.....	20
MAINTENANCE.....	21

SAFETY INFORMATION

Any other use will be deemed improper and may result in severe injury or damage to property. The manufacturer and dealers will not accept any liability for damage caused by improper use. What's more, the device warranty becomes void in such cases.



WARNING

Failure to observe these warnings can lead to electric shock or fire, or damage the charging device.

- ◆ If damage occurs while charging, disconnect the charging device immediately from the power mains, if possible by switching off the mains fuse/circuit breaker. Do not touch any electrically live parts.
- ◆ Never operate the device near ex-plosive vapours or gases, switching operations within the device can generate tiny electric.
- ◆ Never touch the contact surfaces of the charging device. Do not insert any objects into the charging equipment connector faces.
- ◆ Do not attempt to modify or repair your charging device in any way yourself. Never open the housing, and do not make any changes to the adapters and/or extension cables.
- ◆ Do not plug the device into power outlets through which water could ingress the device. Do not immerse the charging device in water.
- ◆ Never disconnect the device connectors while the device is electrically live (i. e. while charging a vehicle), As this can lead to fouling of the connector plug contacts and damage the charging electronics. Always stop the charging process first at the controls inside the vehicle.
- ◆ Protect the plug connectors and power sockets against humidity and moisture. Always keep the plugs and the vehicle end coupling dry. Unplugged connectors are not watertight. Always cover them with the protective caps when not in use.
- ◆ Do not let children play with the packaging material or the charging device.

PRODUCT INFORMATION

Power and Vehicle connector

 UK plug (max.13A)

 Schuko (max.16A)

 CEE16/32(1-phase)

 CEE16(3-phase)

 Type 1(SAEJ1772 North American Standard)

 Type 2 (IEC62196-2 European Standard)

 Type GB (GB/T20234 China Standard)

 NACS Tesla(SAE J3400)

Model number definition

EVB □ □ □ □
 ① ② ③ ④

	Classification	Symbol	Meaning of the symbol
①	Basic type	EVB	B series EV charger
②	Rated power	03	1-phase 16A
		07	1-phase 32A
		10	1-phase 40A
		11	3-phase 16A
③	Charging modes	B	Mode 2
④	Charging interface	T2	Type2(IEC62196-2)
		T1	Type1(SAE J1772)
		GBT	GB(GB/T20234)
		NACS	Tesla(SAE J3400)

Specifications

Electrical Specifications

Phase Number	1-phase			3-phase
Product Model	EVB03B	EVB07B	EVB10B	EVB11B
Rated Voltage	AC110V/240V			AC400V
Input Frequency	50/60Hz			
Max.output Current	16A	32A	40A	16A
Max.output Power	3.7kW	7.4kW	9.6kW	11kW
Cable Specification	3x2.5mm ²	3x6mm ²	9AWG	5x2.5mm ²

Protection

Over voltage protection	Yes
Under voltage protection	Yes
Over load protection	Yes
Short circuit protection	Yes
Leakage protection	Yes
Over-temp protection	Yes

Function and Accessory

LED indicators	Yes
LCD screen	2.4-inch
RCMU	Type B (AC 30mA+DC 6mA)
Current adjustment	Yes
RFID	Yes
WIFI/Bluetooth	Yes (WIFI 2.4GHz)

Working environment

Protection degree	IP 67
Operation temperature	-30℃~55℃
Relative humidity	≤95%RH
Operating elevation limit	≤2000m
Cooling	Natural air cooling
Standby power consumption	<3W

Mechanical parameters

Charging cable	5m (Standard configuration)
Control box	HxWxD=200mm*90mm*52mm
Weight	≤3kg
Colour&Material	Black;PC

Standard&Certificate

Standard	IEC 62752:2016/COR1:2019
Certificate	CE,RoHS

OPERATION

Overview

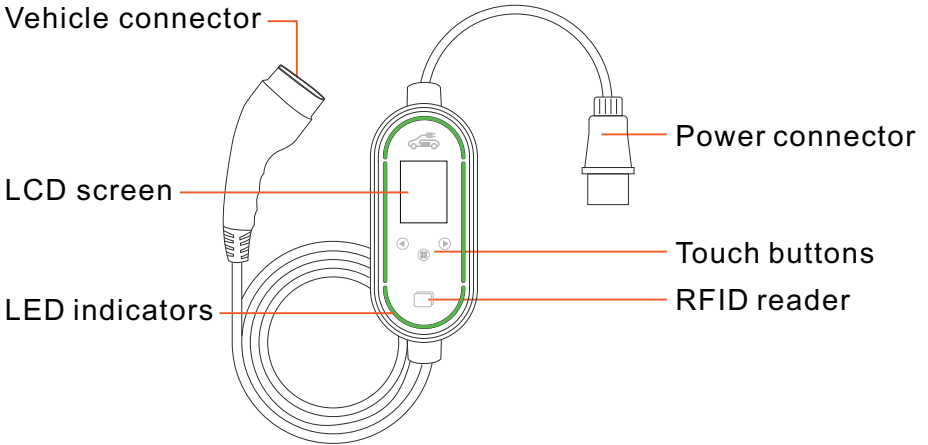

LED indicators

Status	Power On			Charging Standby	Setting Mode
Indicator Light	Light	Light	Meteor	Breathing	Light
Status	Reservation Charging	Waiting Car Signal	Charging Finished	Charging Mode	Fault Mode
Indicator Light	Meteor	Breathing	Light	Meteor	Flashing

Touch buttons



LCD screen

The LCD screen of the device can view status, safety warnings, charging records, and settings.

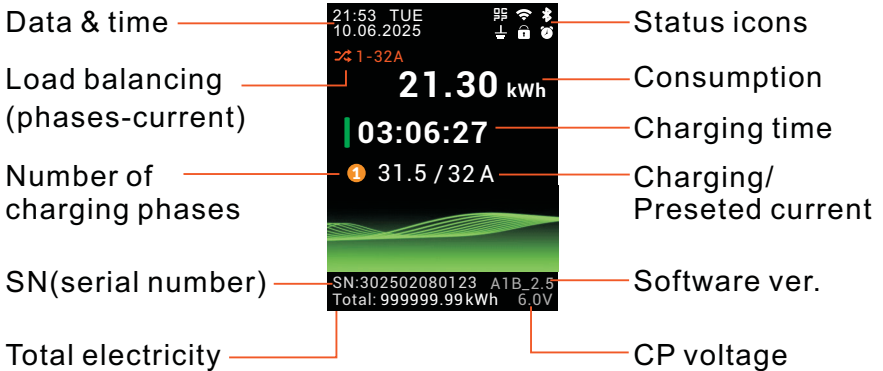

Icon	Connotation	Icon	Connotation
	Bluetooth enable		Reservation enable
	Bluetooth connected		PIN lock enable
	Wi-Fi connected		OCPP disconnected
	Wi-Fi exchange data		OCPP connected
	Grounding connected		

Status display



Charging Standby

Touch button

- ◀ No reaction
- ▶ Enter [Charging history] page.
- ☰ Enter [Settings] page, if PIN is enabled, enter the [Unlock] page.

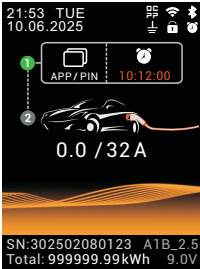

Reservation charging

Swipe RFID, use APP or enter PIN to skip countdown for charging.

Touch button

- ◀ No reaction
- ▶ No reaction
- ☰ Enter [Unlock] page, unlock and start charging.

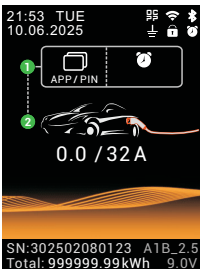

Waiting Car Signal

During the process of waiting for the vehicle signal, step 1 (green circle) remains on and step 2 flashes.

Touch button

- ◀ No reaction
- ▶ No reaction
- ☰ No reaction

Status display



Charging Mode-1

Touch button

- ◀ No reaction
- ▶ Enter [Charging Mode-2] page.
- ⊞ No reaction

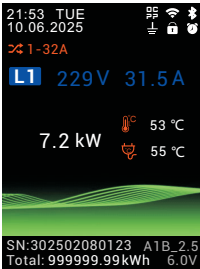

Charging Mode-2

Display voltage and current ,charging power, temperature.

Touch button

- ◀ Enter [Charging Mode-1] page.
- ▶ No reaction
- ⊞ No reaction

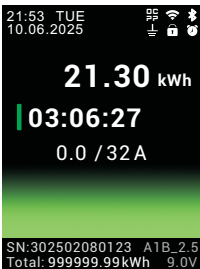

Charging Finished

Display consumption and total charging time.

Touch button



- ◀ No reaction
- ▶ No reaction
- ⊞ No reaction



Fault Mode

Display fault information, fault codes, and handling methods.



Touch button

-  No reaction
-  No reaction
-  Enter [Settings] page, if PIN is enabled, enter the [Unlock] page.

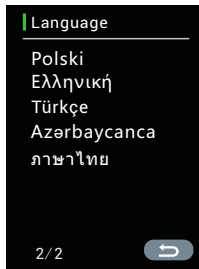
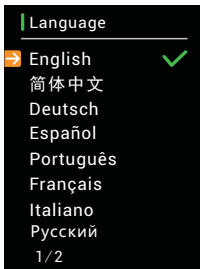
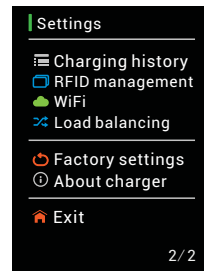
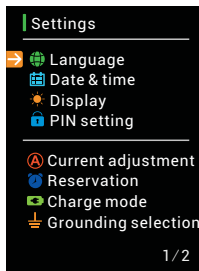
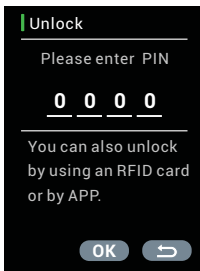
Setting display



Button function description

-  Move the cursor up or left, it will be displayed in orange. If the setting is numerical parameter, the button is to decrease number.
-  Move the cursor down or right, it will be displayed in orange. If the setting is numerical parameter, the button is to increase number.
-  Confirm the selection of the orange item. If the setting is on/off, the button function is on or off.

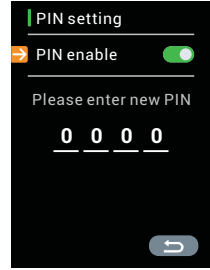
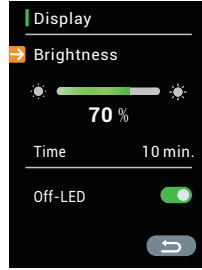
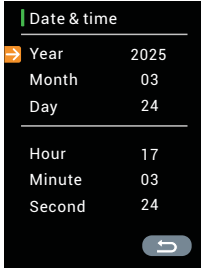

Data&time

If the device is used for the first time or has not been used for more than 20 days, please set the date and time after turning it on. Incorrect time will affect the scheduled charging function.

Display

The LCD brightness can be adjusted from 10% to 100%. Turn off the screen after the set delay time without touching the button, If Off-LED is enabled, the LED will turn off simultaneously with the LCD.

PIN setting

When the PIN is turned on, PIN code needs to be entered to check the Menu, and the  icon on the status display page will light up.

If you forget your PIN, touch the  button, use RFID or APP to unlock, enter the [PIN setting] page of the settings menu, close the PIN or reset the PIN.

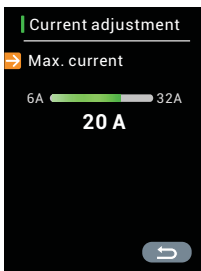

Current adjustment

Set appropriate charging current according to the capacity of the power grid, adjustable step 1A.

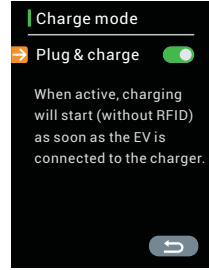
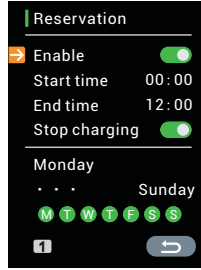
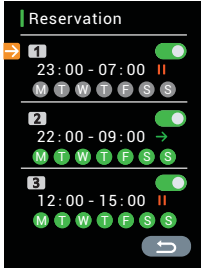

Reservation

Three reservations can be set, reservation can be achieved between the start and end times. If the stop charging is enabled, charging will pause upon the stop time; otherwise, it will continue until the battery is fully charged, and it needs to meet the week setting. After the reservation is enabled, the  icon on the status display page will light up.

Charge mode

Once Plug & charge is enabled, you can start charging when the vehicle plug connected, no other authorization required.

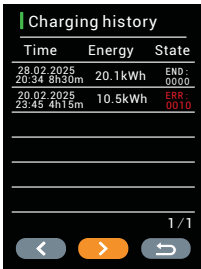

Charging history

The device can store up to 30 records, which can be viewed through the left and right buttons (turn orange and touch the  button).

Note: After accumulating 30 charging records, the former records will be overwritten one by one.

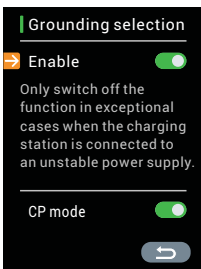

Grounding selection

The charger is installed in an ungrounded or poorly grounded power grid, and grounding can be turned off.

CP mode is designed to be compatible with certain vehicle models that trigger EV diode fault, simply enabling it will allow for normal charging.

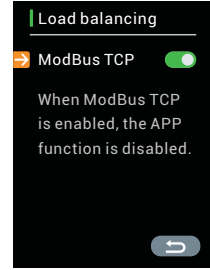
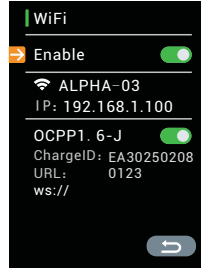
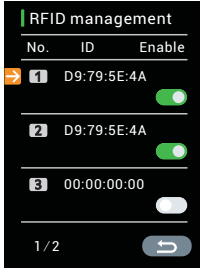

RFID management

RFID can be added or disabled, with maximum of six cards added and saved.

Add RFID: The cursor stays on the ID option, and after touching the  button, the ID will turn orange. Then approach the new card to the swiping area on the charger.

Wi-Fi

The device needs to be set with wireless name and password through the APP, and you can also set static IP address. The ChargID and URL for OCPP need to be set via the APP.

Note:

After enabling OCPP, the app will not be able to connect to chargers. The URL does not need to contain a ChargID, but it needs to end with a '/' .

OCPP setup steps:

1. Successfully bind the charger with APP via Bluetooth.
2. Set up WiFi to successfully connect to the network.
3. Configure OCPP parameters on the settings page using the APP.
4. Enable OCPP on the charger's LCD.

Load balancing

The device can be communicated through ModBus TCP in WiFi mode. After enabling load balancing, control the current during the charging process through the enabled communication mode.

Note: After enabling load balancing, the app will not be able to connect to chargers.

Start charging

1. Connect the power plug of the charger to a grounded outlet, wait for the device to enter charging standby.
2. Couple the vehicle-end connector of the device to the vehicle's charging port.
3. Enter the reservation page(If reservation is enabled). Swipe RFID, use APP or enter PIN to skip countdown for charging.
4. Wait for the vehicle authorization signal, and then enter the charging mode.



Reservation charging

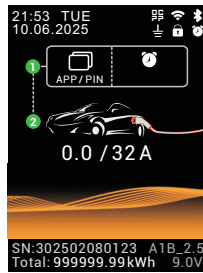

Waiting Car Signal

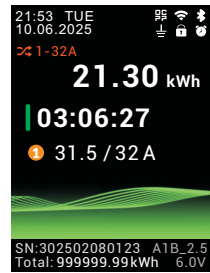

Charging Mode

Stop charging

1. Stop the charging process at the controls inside the vehicle, this releases the lock on vehicle's charging coupling.
2. First disconnect the connector coupled to the vehicle, then unplug the connector plug from the power socket or the charging station.

Installing the App

1. Download and install the app on Google Play or App Store.
2. Allow Bluetooth functionality on your smartphone or tablet, and enable **location** permission on the EV-Charger app.



EV-charger
Utilities

EV-Charger

EV-Chargergo



Registration

You must register before using the APP.

Note: It is not technically possible to use the app without registering.

Please note the privacy policy for the processing of your personal data in the app.

1. Open the EV-charger app, select the language for the app in the top right-hand corner and click on **Register** (Fig. 6)
2. Enter your **email address** and click on **Get code**. You will receive an email with a **6-digit code**. Enter the code in the **Verification code** field.
3. Enter a secure password that you can save in a password manager or memorise.
4. Click on **Register**. Your user account is created and you are automatically logged into the app (Fig. 7).

Fig.6

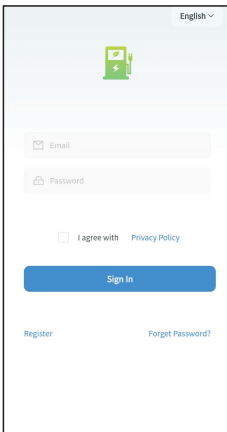
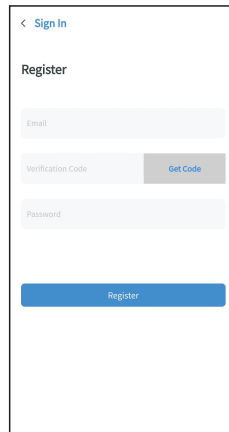

Fig.7



Connecting the charging station

The charging station is first connected via the Bluetooth connection. Once the connection has been established, the wallbox can be connected via WiFi.

1. Switch on the charging station and hold the smartphone or tablet within range of the charging station.
2. Start the app and tap on the **QR code symbol** or the **plus symbol** in the top right-hand corner (Fig. 8).
3. Now scan the QR code of the charging station, which you will find on the operating instructions and under the housing cover of the charging station.
4. After the QR code has been scanned, enter the **6-digit PUK** and click on **Confirm add** (Fig. 9).
5. The app now searches for the charging station and adds it automatically.

Note: Accept the authorisations for camera and location that the app requests. Without the permissions, the code cannot be scanned and the charging station cannot be found.

Fig.8

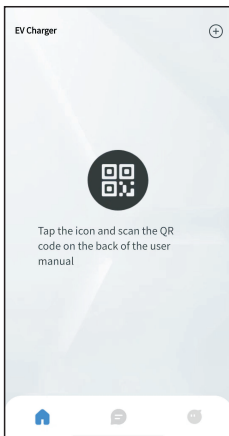
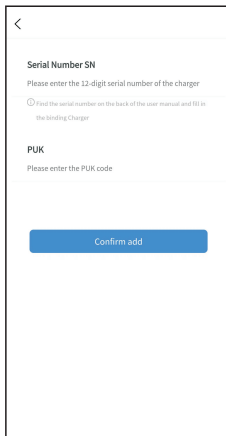

Fig.9

The screenshot shows two input screens. The top screen is titled 'Serial Number SN' and asks the user to 'Please enter the 12-digit serial number of the charger'. It includes a tip: 'Find the serial number on the back of the user manual and fill in the Serial Number field'. The bottom screen is titled 'PUK' and asks the user to 'Please enter the PUK code'. A blue button labeled 'Confirm add' is at the bottom.

WiFi connection

Once the charging station has been connected via Bluetooth, you will find it in the app overview. To connect the charging station to an existing WiFi network, proceed as follows:

1. Select the charging station in the app on the overview page (Fig.10).
2. Tap on the **WiFi symbol**.
3. Enter the **name** and **password** of your WiFi network and click on **OK**. (Fig. 11).
4. The charging station will now attempt to connect to the data you have entered.
5. As soon as the charging station is connected to the WiFi, the **WiFi symbol** lights up on the display of the charging station. Check that the charging station is connected to the network by opening the **WiFi menu** of the charging station.
6. Go back to the overview in the app by tapping on the **arrow** at the **top left** and refresh the view by **swiping from top to bottom** in the app.
7. The charging station is connected to WiFi when „**Online**“ is displayed in the overview page and the **WiFi symbol** on the status page is blue (Fig. 12).

Note: Leave the DHCP switch switched on to enable automatic IP address assignment.

Fig.10

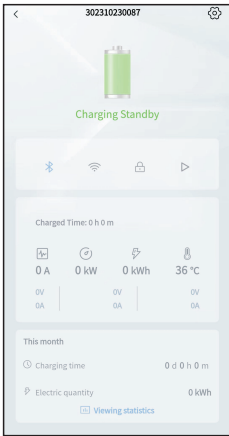

Fig.11

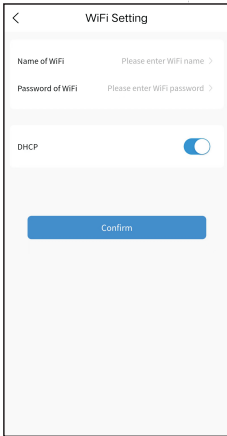
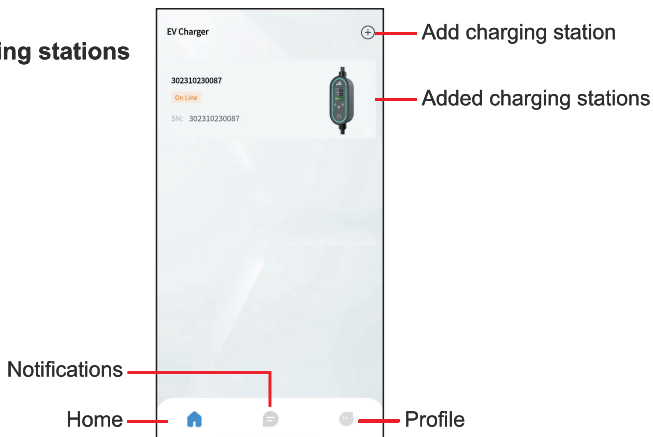

Fig.12



App Overview

Overview of charging stations



Detail page of charging station

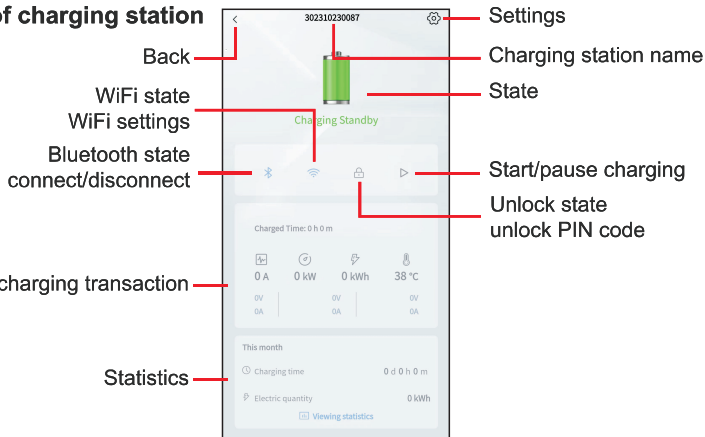

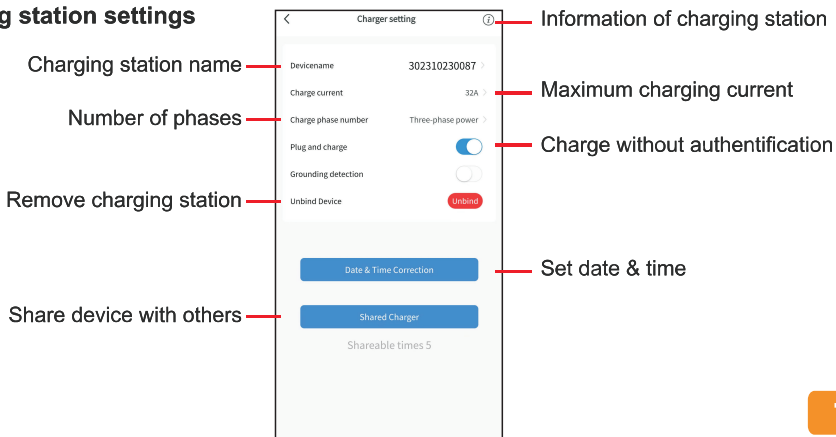

Charging station settings

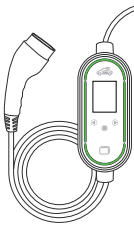

TEMPERATURE CONTROL (optional)



Power plug with temperature sensor

-  UK plug (max. 13A) CEE16/32
-  Schuko (max. 16A)

The power plug contains a temperature sensor inside. This temperature sensor is a negative temperature coefficient thermistor (NTC), which can feedback the temperature change of the power plug in real time.

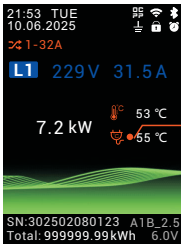

Real time Temperature

Charging Mode

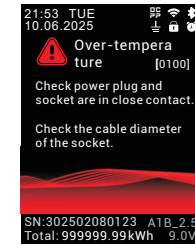

Fault status

Control process

- ◆ When the temperature of the power plug reaches up to 95°C and lasts 10 seconds, the temperature control protection is turned on, the charging is stopped, and the LCD screen displays the over-temperature fault.
- ◆ After waiting for the power plug cooling down to 75°C and lower and lasts 10 seconds, the device will automatically start to continue charging again.

Fault handling

- ◆ Check power plug and socket are in close contact.
- ◆ Check the cable diameter of the socket.
- ◆ Do not leave the device exposed to sunlight, but also do not cover it.

INSTALLATION (optional)

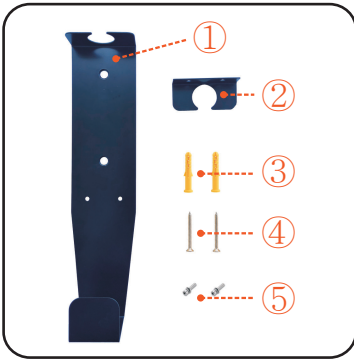

- ① Wall Bracket
- ② Bottom Bracket
- ③ Expansion Plugs
- ④ Self-tapping Screws
- ⑤ Combination Screws

Material: 5mm thick aluminum plate, anodized

Installation steps



Step1



Step2



Step3

Step 1: Put the **wall bracket** in a proper position on the wall, mark the position of the top two screw holes on the wall using a pencil.

Step 2: Put down the wall bracket and drill the holes just marked. Insert the **expansion plugs** and fix the wall bracket to the wall using **self-tapping screws**.

Step 3: First insert the device into the upper mounting hole of the wall bracket. Then into the round hole of the **bottom bracket** and fix it on the wall bracket using **combination screws**.

FAULT HANDLING

The device is automatically protected in the event of the fault. The fault information and handling methods are as follows.

Fault information	Handling method
Both the LED and LCD screen are not on	<ul style="list-style-type: none"> ◆ Check whether the power supply and distribution are normal. ◆ Check breaker is tripped, and open the breaker after troubleshooting.
LED on, and LCD screen not on	<ul style="list-style-type: none"> ◆ LCD connection cable is loose or LCD is damaged.
Waiting car signal for a long time	<ul style="list-style-type: none"> ◆ Battery of car is full, the car is in the reservation delay charging mode, or the vehicle connector is not properly connected. ◆ Disconnect and reconnect the vehicle connector.
Ground Fault Code: 0001	<ul style="list-style-type: none"> ◆ The device is not grounded, check the input power cable.
RCMU Fault Code: 0002	<ul style="list-style-type: none"> ◆ The RCMU is damaged and needs to be returned to the factory for repair.
Over voltage Code: 0004	<ul style="list-style-type: none"> ◆ Check whether the input cable is connected correctly. ◆ Check whether the input voltage is abnormal.
Under voltage Code: 0008	<ul style="list-style-type: none"> ◆ Check whether the input cable is reliably connected. ◆ Check whether the input voltage is abnormal.
Leakage Fault Code: 0010	<ul style="list-style-type: none"> ◆ Check whether the vehicle connector and it's cable are damaged or wet. ◆ Recover after pulling out the mains connector.

Fault information	Handling method
Over current Code: 0020	<ul style="list-style-type: none"> ◆ Check whether the vehicle connector is correctly connected. ◆ Check whether the on-board charger is normal.
CP voltage Code: 0040	<ul style="list-style-type: none"> ◆ Check the vehicle connector and charging socket of EV. ◆ Disconnect and reconnect the vehicle connector.
Short circuit Code: 0080	<ul style="list-style-type: none"> ◆ Check whether the vehicle connector and its cable are damaged or wet.
Over temperature Code: 0100	<ul style="list-style-type: none"> ◆ Check power plug and socket are in close contact. ◆ Check the cable diameter of the socket.
EV diode Fault Code: 4000	<ul style="list-style-type: none"> ◆ Diode fault of CP signal at the vehicle end. Please check the vehicle or enter the settings menu to open CP mode.

MAINTENANCE

- ◆ Check whether the join point of the input terminal is in good contact and whether there is any abnormality.
- ◆ If plugs get wet, allow them to dry before using them.
- ◆ Always fit the device with the protective caps when not plugged in.

ELECTRIC AND HYBRID VEHICLES

Model: EVBxxB series
Rev. 0.4